

351S36N

Cooking Performance Group S36-N Natural Gas 6 Burner 36" Range with Standard Oven - 210,000 BTU



Item #: 351S36N Qty: _____

Project: _____

Approval: _____ Date: _____

Features

- (6) 30,000 BTU open top burners with cast iron lift-off grates for easy cleaning
- Rugged stainless steel front and aluminum sides; porcelainized oven bottom
- 9 1/2" deep back shelf and 4 1/2" plate rail for added storage and safety
- Compatible caster set available for purchase
- Requires a natural gas connection; located on the right side of the unit

Technical Data

Width	36 Inches
Depth	32 5/8 Inches
Height	60 3/8 Inches
Oven Interior Width	26 7/8 Inches
Oven Interior Depth	25 7/8 Inches
Oven Interior Height	13 7/8 Inches
Burner BTU	30000 BTU
Burner Style	Grates
Control Type	Manual
Gas Inlet Size	3/4 Inches
Installation Type	Freestanding
Maximum Temperature	550 Degrees F
Number of Burners	6 Burners
Number of Ovens	1
Number of Racks	2
Oven BTU	30000
Power Type	Natural Gas
Range Base Style	Standard Oven
Total BTU	210000 BTU

Certifications



ETL US & Canada



ETL Sanitation



3/4" Gas Connection

351S36N

Cooking Performance Group S36-N Natural Gas 6 Burner 36" Range with Standard Oven - 210,000 BTU



Plan View

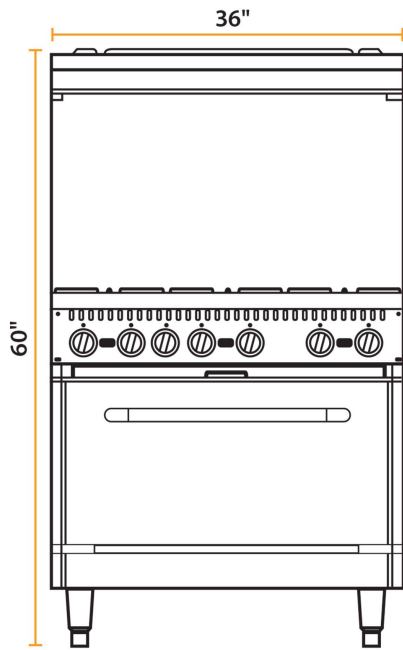

FRONT

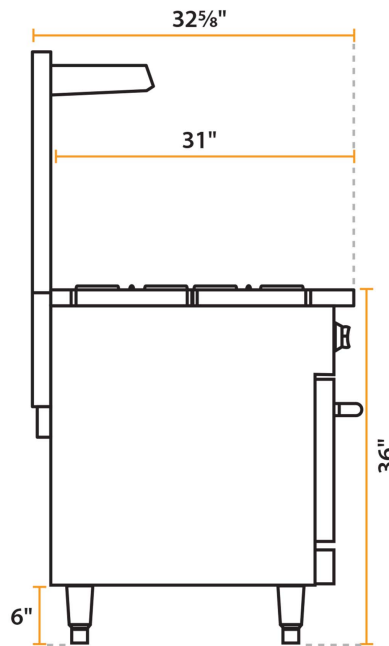

SIDE

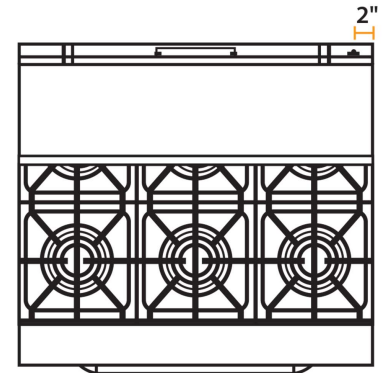

TOP

Cooking Performance Group S36-N Natural Gas 6 Burner 36" Range with Standard Oven - 210,000 BTU



Notes & Details

Boost your kitchen's efficiency, reliability, and overall performance with this Cooking Performance Group S36-N gas range! This natural gas range boasts (6) 30,000 BTU open top burners to deliver the impressive cooking performance you demand. The independently-controlled burners mean you can simultaneously execute a wide variety of tasks while their 12" x 12" heavy-duty cast iron grates support your sauce pans, fry pans, and other cookware. These rugged grates allow you to confidently boil, saute, and simmer as needed while effortlessly sliding even the heaviest stock pots from one burner to another. A 4 1/2" plate rail gives you a bit of extra room to work with and combines with a 9 1/2" deep back shelf that holds go-to seasonings and supplies to maximize your cooktop efficiency.

A 30,000 BTU standard oven makes this unit even more versatile by giving you a convenient way to warm your delicious foods or even do a bit of baking for your dessert menu! The oven's temperature can be adjusted from 250-550 degrees Fahrenheit to accommodate virtually any recipe. With 2 chrome plated racks that can be used in 4 different positions, you can easily arrange the oven to best complement your specific needs.

This 36" range features a rugged stainless steel front and durable aluminum sides that are not only designed to provide you with years of trouble-free performance, but are also extremely simple to clean! The cast iron grates lift off for a simple, thorough cleansing while the deep pull-out crumb tray further expedites end-of-day cleanup. And, thanks to the porcelainized bottom, maintaining a spotless oven is easier than ever. 6" adjustable stainless steel legs ensure that your unit is level and allows you to easily clean underneath for a safe and sanitary kitchen. A natural gas connection, located on the right side of the unit, is required for operation.

⚠ WARNING: This product can expose you to chemicals including lead, which are known to the State of California to cause cancer, birth defects, or other reproductive harm. For more information, go to www.p65warnings.ca.gov.